

Genproof 13 Tubular Light

A unique IP69K luminaire suitable for commercial & industrial area applications, especially applicable to humid harsh environments. Smooth housing made of IK10 polycarbonate, aluminum heatsink, stainless steel 316 screw and end caps. Honeycomb diffuser in clear PMMA or PC housing are optional which achieves a low UGR (60deg beam UGR < 12, 90deg beam UGR < 16). Frosted anti-glare housing is also optional for visual comfort.



2 Lancaster Place
Electron Lane
Lanseria Corporate Estate
Lanseria
+2711(0) 4620251

genesis  ne
www.genesisonlighting.com
sales@genesisonlighting.co.za

Product Specification

LED Tubular Light

Product APPLICATIONS

Suitable for:
 Food processing lighting or any other harsh environment where a heavy-duty, super-bright alternative is needed.
 Farm Lighting; Poultry Lighting, Agricultural application
 Other; Commercial, Warehouse, Parking, Supermarket lighting.

Product FEATURES

High protection IK10 IP66 IP69K ideal for food industry, laboratories or any other harsh environment (*frosted PC housing is standard, clear PC housing is optional*).
 Low UGR version for use in commercial applications.
(use honeycomb diffuser or frosted PC housing).
 Anti-corrosive version, for use in high chemical applications such as animal farms, swimming pool and laboratories
(use PMMA housing High efficiency up to 130lm/w.(150lm/w optional)
 Intelligent control for energy saving



TECHNICAL DATA

MODEL NO.	TP0603N/205013A TP0603N/205013B	TP1103N/405013A TP1103N/405013B	TP1403N/505013A TP1403N/505013B
WATT(W)	20	40	50
LUMEN	2 600	5 200	6 500
RATED INPUT VOLTAGE(V)	220-240 VAC		
POWER SUPPLY	PHILIPS Xitanium Driver		
SURGE PROTECTION	1kV line-line, 2kV line-earth		
EFFICACY (4000K, RA70)	130(±5%) LM/W@RA80 optional 150(±5%) LM/W		
CORRELATED COLOR TEMPERATURE	5000K (3000K & 4000K optional)		
COLOR RENDERING INDEX	Ra80		
BEAM ANGLE	A - 120° , B 60°/ 90°		
FREQUENCY	50 / 60 Hz		
POWER FACTOR	≥0.91		
IP RATING	IP66 & IK10&IP69K		
LUMINAIRE NETWEIGHT KG	1.10k±0.2kg	1.10k±0.2kg	1.96±0.2kg
PRODUCT DIMENSION (MM)	120*84*600	120*84*1128	120*84*1390
MATERIAL	Alu Alloy + Stainless Steel + Polycarbonate Optical Diffuser		
DIMMABLE	Non Dimmable (Dimmable optional)		
FINISH	-		
FINISHING COLOUR	Milky white as standard (Clear optional)		
LIFETIME (HR)	>50,000Hrs (Ta=30°C@L77)		
INTELLIGENT CONTROL	1-10V and Dali optional		
OPERATING TEMP.(°C)	-30°C ~ 40°C		
MOUNTING OPTION	Suspension mount /ceiling and wall mount		

Product DIMENSIONS

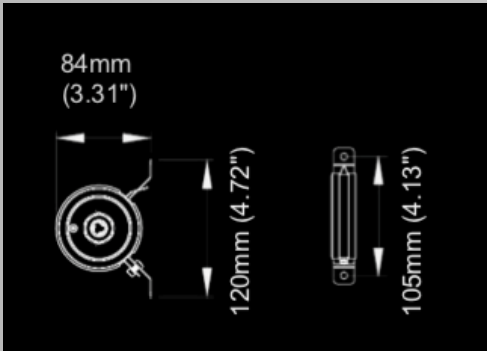
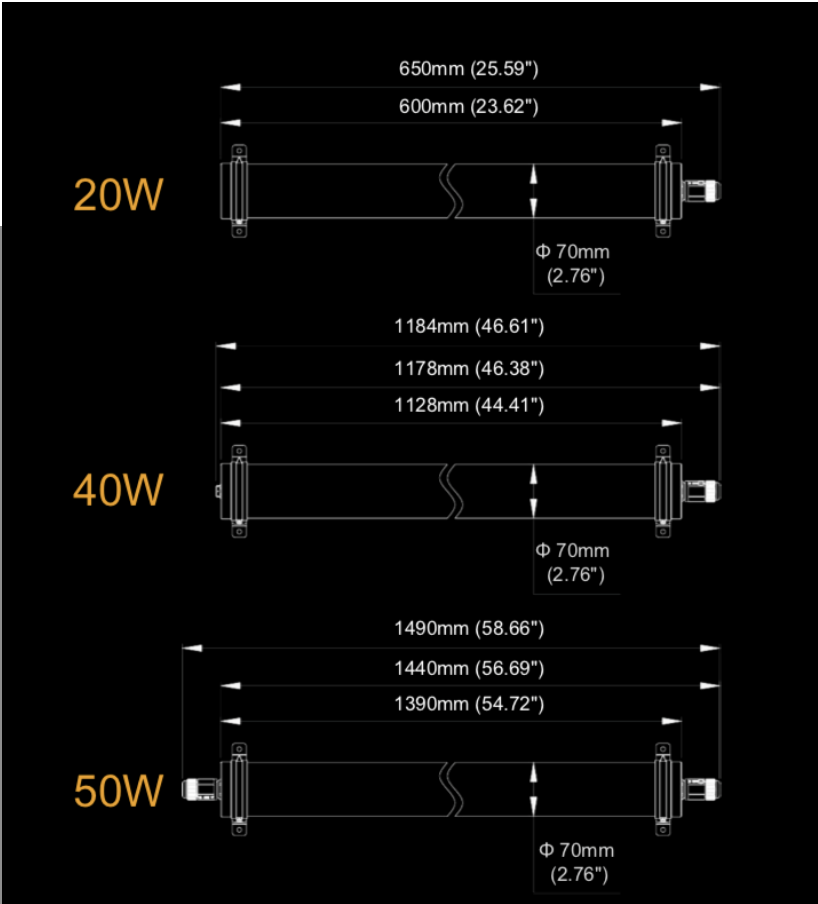

Product PHOTOMETRY

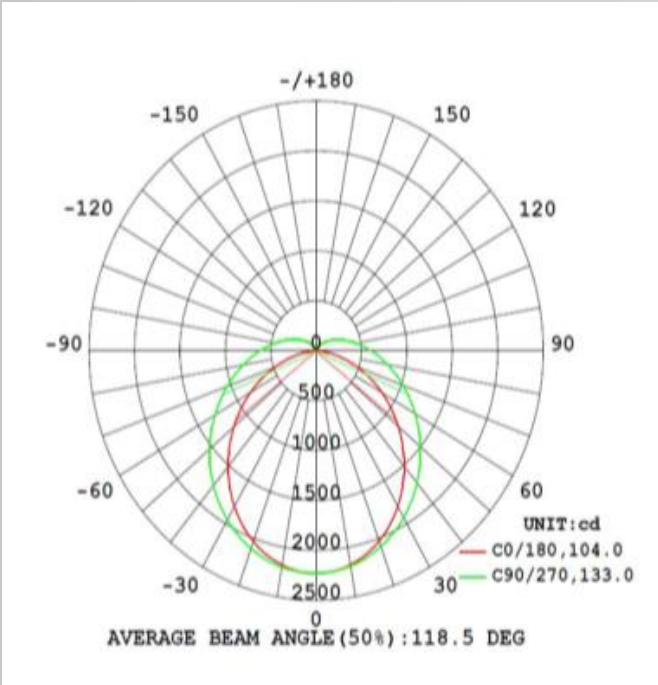

Product INSTALLATION

84 (3.31")
120 (4.72")
105 (4.13")
Φ70 (2.76")

Steel wire sling
2pcs
2pcs

POWER	A(mm/in)	B(mm/in)	C(mm/in)	D(mm/in)
20W	600(23.62")	650(25.59")	656(25.83")	700(27.56")
40W	1128(44.41")	1178(46.38")	1184(46.61")	1228(48.35")
50W	1390(54.72")	1440(56.69")	1446(56.93")	1490(58.66")

A-Length of the body;
B-Length of the body with single connector;
C-Length of the body with single connector and vent;
D-Length of the body with double connectors.

Product Specifications	20W	40W	50W
Weight (Driver included)	2.43±0.44Lbs (1.10±0.2kg)	3.57±0.44Lbs (1.62±0.2kg)	4.32±0.44Lbs (1.96±0.2kg)
Input Voltage	220-240 VAC		
Working Temperature	-30°C to +40°C(-22°F to +104°F)		
Storing Temperature	-40°C to +70°C(-40°F to +158°F)		

A. Ceiling mounting

- M5x4.5
2.0Nm
- M4x15
1.2Nm
1. small rubber plug
2. large rubber plug

When the outer diameter of the power cord is 5-7.5mm, use small rubber plug with waterproof connector. When the outer diameter of the power cord is 7.5-10mm, use a large rubber plug with waterproof connector.
-

B. Suspension mounting

-
- Press the lock
Pull out
Adjust the height of lamp and lanterns
M4x15
1.2Nm
- Adjust the Steel wire sling B to balance the fixture